



BUSINESS PROFILE

www.nutekgroup.co.za



NUTEK

GROUP (PTY) LTD

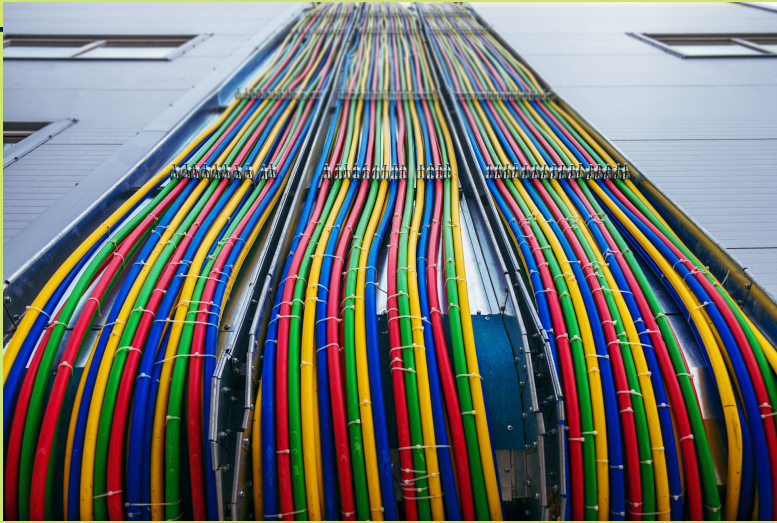

THE COMPANY

Nutek Group is a business entity that was formed in 2022 by Freman Ncwandule. He has vast and intensive skills, experience, and knowledge in the electrical field.

Nutek Group is a self-funded and motivated business unit that intends to render professional services in the electrical engineering field and related engineering fields with the potential to grow above the margin and to create job opportunities within our communities for economic empowerment.

Nutek Group strives to offer excellent services, and maintain solid business relations and a high level of good workmanship. We at Nutek Group promote outstanding performance and continuous improvement to meet customer demands. The business is prepared to advance into new technology systems as needed to. We intend to share the knowledge and to develop the previously disadvantaged candidates within and outside our team.

www.nutekgroup.co.za



MEET OUR TEAM



Ncwandule Freman Twanano

CEO Director

- Trade certificate Electrician)
- National Certificate (N5), Electrician
- Hydraulic maintenance certificate

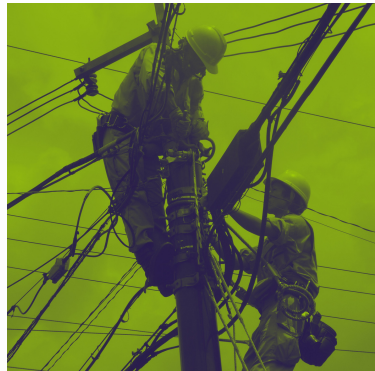



VISION & MISSION



Vision

Nutek Electrical strive to be recognized as one of the leading World class electrical construction company in its core business of activities both within South Africa and abroad. Promoting, fostering and encouraging capacity electricity, development and skills transfer.



Mission

To provide strategic and technical value to our customers by designing, building, and maintaining cost-effective electrical systems (renewal energy solutions) with an emphasis on energy saving.

OUR SERVICE



*Issuing of Certificate
Of Compliance
(COC).*



*Industrial/commercial
electrical installation
and commissioning.*



*Electrical panel
design and wiring.*



*Industrial automation
designing.*



*Electrical projects and
construction work.*



*PLC programming
and fault finding.*



*Electrical repairs,
maintenance, callouts &
shutdowns.*



OUR FOCUS

The company projects high prospects of a brand meeting customer demand and transforming from one level to another as technology changes and advances.

We are fully prepared to develop and acquire substantial knowledge and experience as a newly formed business unit in the market.

Our focus includes:

01 Clientele

Any suitable and potential client seeking our recommended professional services

02 Market focus

Our focus is mainly on domestic, commercial, and industrial repairs, electrical installations, and commissioning of equipment/ machinery. To be involved in projects, shutdowns, and not limited construction work.

03 Objective

To provide engineering solutions within our communities and to multiply other revenues to create jobs and to maintain a sustainable business entity.

04 Quality Assurance

We always aim to deliver exceptional, reliable service and good workmanship to our customers/ clients. We strive for continuous improvement to meet our customer's demands.



WHY CHOOSE US



Our 24-hour callout service; unparalleled after-sales maintenance packages, and guarantees on all works and products guaranteed by SABS have led us to become the leaders of electrical services in the industrial, residential, and commercial sectors. Responding to the needs of our customers with superior products and service is what being "Always On" means, but don't take our word for it – contact us today and discover Nutek quality for yourself.

www.nutekgroup.co.za



NUTEK

GROUP (PTY) LTD

HOW IT WORKS



Meeting with clients: An important part of an engineering consultant's job is meeting with clients, sometimes many during a single week. They use these meetings to learn about their clients' requirements and to develop solutions.

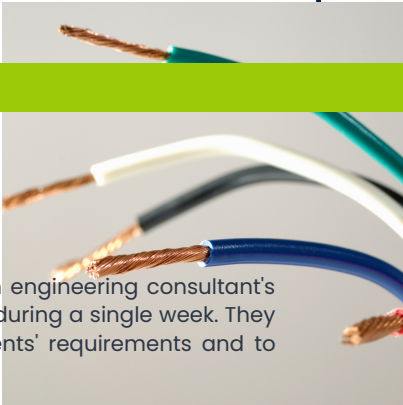

Assisting with project planning: After learning about a new project and their client's expectations, engineering consultants often begin the planning process. They use their knowledge of engineering to plan solutions that meet client needs.

Visiting work sites: Engineering consultants often visit work sites, like manufacturing plants or construction sites, during the planning process. They may also maintain a continuous presence at the site until a project is complete.

Providing expert advice: One of an engineering consultant's primary jobs is to provide expert engineering advice to companies that don't have in-house engineers. Their expertise is often an important asset for companies in the construction and manufacturing industries.



www.nutekgroup.co.za





GET IN TOUCH WITH US

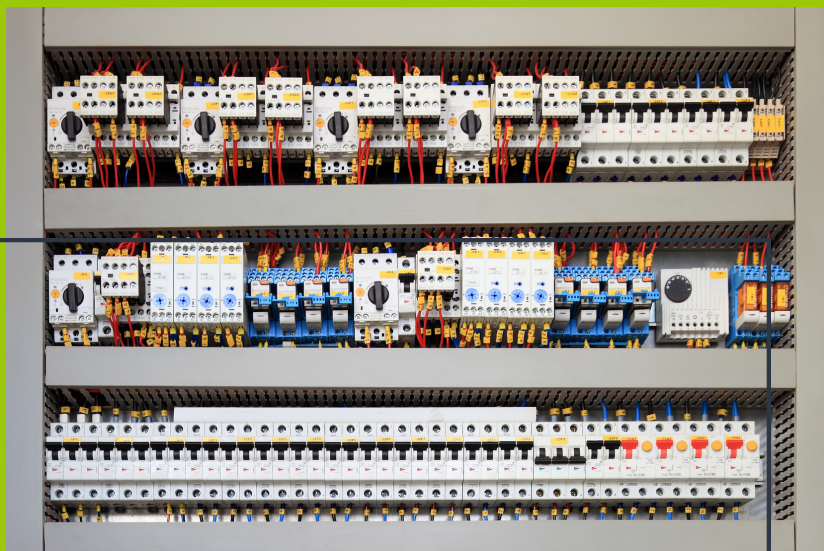

0711366043



tfncwandule@gmail.com



94 Schoeman Street,
Mokopane, Limpopo

104 Ecopark, Xikukwani,
Giyani, Limpopo 0826

www.nutegroup.co.za